



Office of the Chief Investigator
Transport Safety

Rail Safety Investigation
Report No 2017/04

Overcurrent Fault
B2 Class Tram 2109
Plenty Road, Bundoora
11 September 2017



THE CHIEF INVESTIGATOR

The Chief Investigator, Transport Safety is a statutory position under Part 7 of the *Transport Integration Act 2010*. The objective of the position is to seek to improve transport safety by providing for the independent no-blame investigation of transport safety matters consistent with the vision statement and the transport system objectives.

The primary focus of an investigation is to determine what factors caused the incident, rather than apportion blame for the incident, and to identify issues that may require review, monitoring or further consideration.

The Chief Investigator is required to report the results of an investigation to the Minister for Public Transport or the Minister for Ports. However, before submitting the results of an investigation to the Minister, the Chief Investigator must consult in accordance with section 85A of the *Transport (Compliance and Miscellaneous) Act 1983*.

The Chief Investigator is not subject to the direction or control of the Minister in performing or exercising his or her functions or powers, but the Minister may direct the Chief Investigator to investigate a transport safety matter.

SAFETY SUMMARY

What happened

At about 1505 on Monday 11 September 2017, Tram 2109 was operating a scheduled passenger service from Bundoora to Docklands, when the tram lost power and came to a stop. The tram had also lost 24V DC power, so the driver was unable to operate the tram doors. He used the emergency door release and was in the process of commencing evacuation when an explosion was heard, with flames and smoke observed. One passenger was injured during the evacuation of the tram.

What was found

It was found that a series of events led to the fire and explosion. These events were initiated by an electrical short circuit in a traction motor, which in turn resulted in a high fault current in the tram electrical system. The short circuit was caused by arcing between a heavily worn commutator and the brush holder of the motor. The poor condition of the traction motor was previously noted during scheduled maintenance, but the motor was not exchanged as required by maintenance procedures.

Although the tram's main electric supply protection device (line breaker) operated, a flashover (breakdown of insulation resulting in arcing) occurred causing severe damage to the line breaker and its enclosure. It is probable that this flashover was caused by the incorrect installation of the line breaker arc chute or pre-existing damage to the arc runners.

The overhead section providing electrical traction supply to the tram, was fed from two separate substations. The protection devices at each of these substations tripped on the fault current independently and then following automatic line tests, also reclosed independently. Both protection devices tripped again and then again following remote closing by control centre operators. Although the supply was interrupted briefly by the protection devices, it was subsequently reclosed several times with the overhead supply voltage being maintained even though a fault condition persisted. This resulted in the contact wire melting.

What has been done as a result

Yarra Trams have introduced new maintenance instructions to improve maintenance techniques and the timely replacement of traction motors and line breakers.

With respect to the power supply infrastructure, Yarra Trams are introducing new protection standards, power system upgrades and ongoing protection relay upgrades.

Safety message

It is important to complete maintenance tasks with attention to detail and where an item is not serviceable to hold a tram until it can be repaired. Regular review of the effectiveness of risk controls for overhead traction supply networks is important to ensure hazards are mitigated.

TABLE OF CONTENTS

The Chief Investigator

Safety Summary

1. The Occurrence	1
2. Context	2
2.1 Location and environment	2
2.2 Electrical power supply system	2
2.3 Tram	4
2.4 Similar Occurrences	8
3. Safety Analysis	9
3.1 The incident	9
3.2 Traction motor	9
3.3 Line Breaker	10
3.4 Substation overcurrent protection	10
4. Findings	12
4.1 Context	12
4.2 Contributing factors	12
5. Safety issues and actions	13
5.1 Traction motor condition	13
5.2 Substation Circuit Breakers operating independently	13
5.3 Additional safety actions	14

1. THE OCCURRENCE

On 11 September 2017, Yarra Trams B Class tram 2109 was operating Route 86 from Bundoora to Docklands, Melbourne. The tram service started at about 1455 from the Bundoora terminus, Stop 71, and proceeded to tram Stop 64 without incident. At about 1505, the tram was approaching the Greenwood Drive intersection and was between tram Stop 64 and 63 on Plenty Road, Bundoora, when the driver reported hearing a 'bang' and losing all power to the tram controls. At the time the tram was travelling downhill at about 50 km/h and the driver was using the brake to control the speed.

The tram came to a stop and the driver attempted to call the tram control centre from the tram radio. This attempt was unsuccessful due to the loss of power to the radio. He then called the control centre on his mobile phone and informed them of the incident.

After requesting passengers to stay in the tram (in case the tram was electrically alive), the driver inspected the outside of the tram and the overhead wire. He observed the tram overhead wire lying on the ground, across the tracks (Figure 1). The driver also noted a strong burning smell emanating from the tram.

Passengers were then instructed to disembark one at a time and the driver proceeded to assist an elderly lady off the tram. He was assisting the lady through the tram door when there was an explosion and resulting smoke. Passengers then rushed towards the exit and knocked them over in their attempt to exit the tram. The lady fell onto the road from where the driver assisted her to the grass verge. Flames were observed under the tram.

The elderly passenger sustained minor injuries in the incident and was transported to hospital. There were no other injuries.

Once the overhead contact wire was repaired, the power supply was reinstated to the section at 1551.

Figure 1: Traction contact wire lying on the tram tracks



Source: Yarra Trams

2. CONTEXT

2.1 Location and environment

The tram track between Stop 64 and 63 is straight with a descending grade. At the time of the incident, the weather was dry. The temperature at the time of the incident was about 17 °C.

2.2 Electrical power supply system

2.2.1 Substation supply

The power supply for trams in Melbourne is provided by a nominal 600V DC supply through an overhead contact wire to the tram's pantograph and an electrical return path provided by the tram track. The 600V system is made up of interconnected geographical sections, which are supplied from traction substations. For network reliability, each end of a 600V section is normally fed from different substations located at each end of the section. Substations at Bundoora (Bu2) and La Trobe (L2) supplied the section of track at the location of this incident.

The traction substations are supplied from the electrical distribution system by 22 kilovolt (kV), 3 phase 50 Hz, alternating current (AC) supply. This is transformed and rectified at the substations to a line voltage of 600 volts direct current (DC) for the tram traction supply (Figure 2).

Substations incorporate high speed DC circuit breakers (HSCB) to protect the substation equipment, overhead contact wire and the tram traction system. The tripping current for circuit breakers at both the Bundoora and La Trobe substations was set at 3500 A. The overhead supply for both directions of traffic, are connected and fed at each end from different substations by one HSCB in each substation.

These breakers also have an automatic reclosing action. A line test device is provided in each feeder to first check whether a fault condition has cleared following tripping of the breaker. Should the feeder condition indicate a fault is not present, then the reclosing relay is activated, and the circuit breaker will reclose. Typically, the reclosing device is activated after a time delay¹ following the opening of the circuit breaker.

The substation equipment is inspected every four weeks to detect any abnormalities in contacts and arc chutes of feeder panels. High voltage protection equipment is tested every five years. All maintenance requirements for the substation equipment had been carried out as required by the Technical Maintenance Plan (TMP).

¹ The time delay is adjustable to a value between 10 and 30 seconds.

Figure 2: Substation schematic

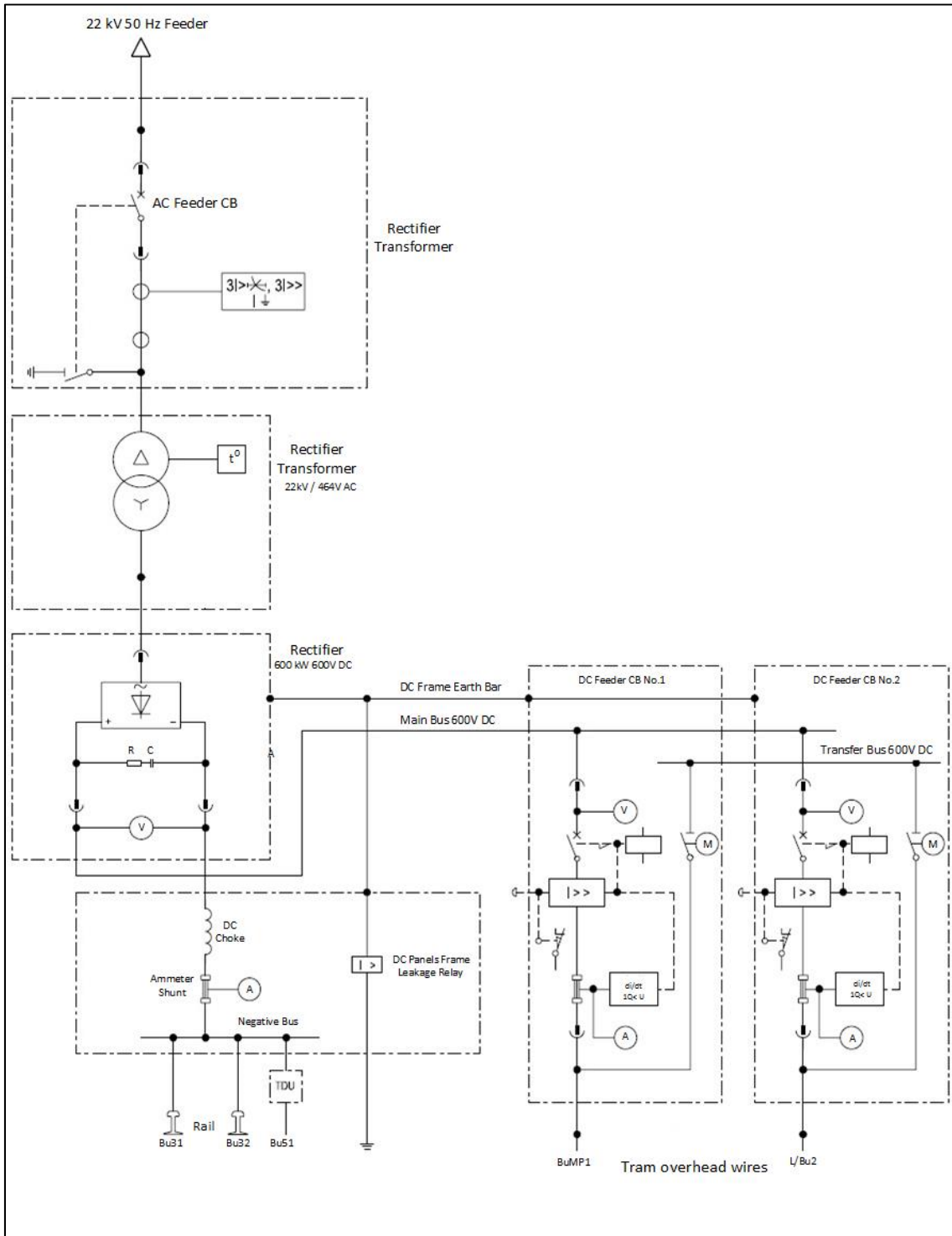

Source: Yarra Trams – Annotated by Chief Investigator, Transport Safety

2.3 Tram

The B2 Class tram is a three door, double articulated wide-bodied vehicle of 23.6 m in length, 3.6 m in height and 2.6 m width (Figure 3). Tram 2109 first entered service in July 1989.

Figure 3: B2 Class Tram schematic

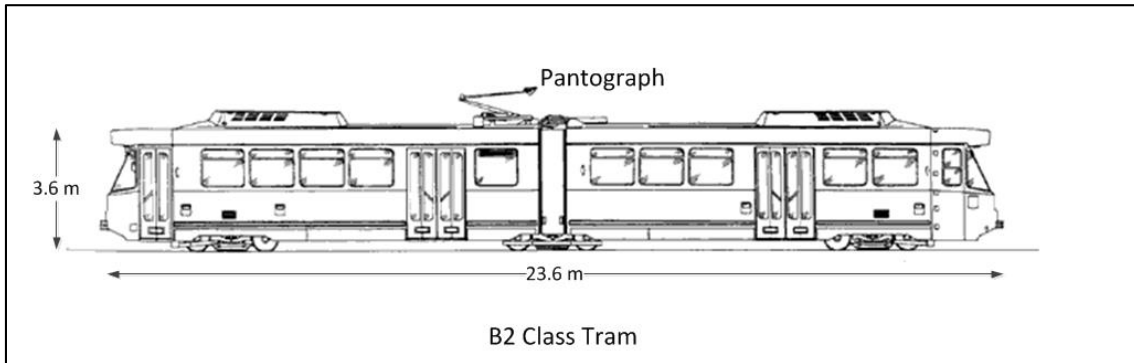

Source: Department of Transport - Annotated by Chief Investigator, Transport Safety

2.3.1 Tram control console

B Class trams are operated by the driver using separate accelerator pedal and a brake pedal that initiates dynamic, disc and track brakes depending on the tram speed and the degree the brake is applied (Figure 4).

Should there be an overcurrent event during the operation of the tram, the line breaker (or main circuit breaker) trips to protect the tram's 600V electrical systems. The driver can reset the line breaker by operating the reset button on the console. The line breaker would reset if the overcurrent fault has cleared.

Figure 4: Tram driver console

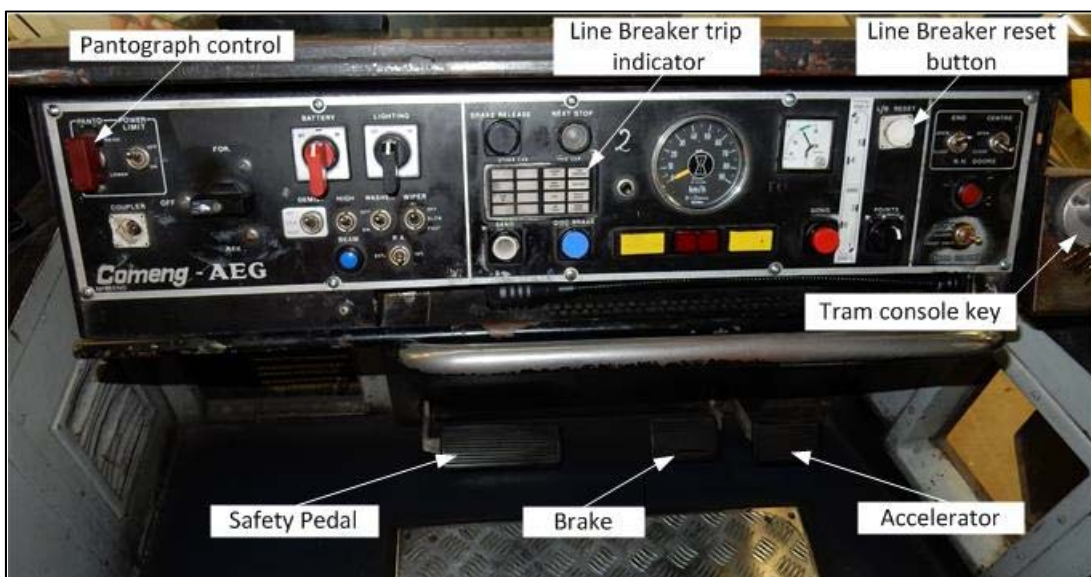

Source: Chief Investigator, Transport Safety

2.3.2 Tram Traction system

When the pantograph of the tram is in contact with the overhead wire, 600V DC power is provided to the line breaker through an Isolating switch (2Q3). Once the line breaker and the motor contactors are closed, the supply is connected to the traction motors through line Diodes, a Reactor and the chopper to control power (Figure 5). Provided the overhead line voltage is receptive², the tram can return energy to the overhead system during regenerative braking. If the overhead voltage is outside these limits, then the tram braking current will automatically divert to onboard resistors.

Figure 5: Tram traction power control system

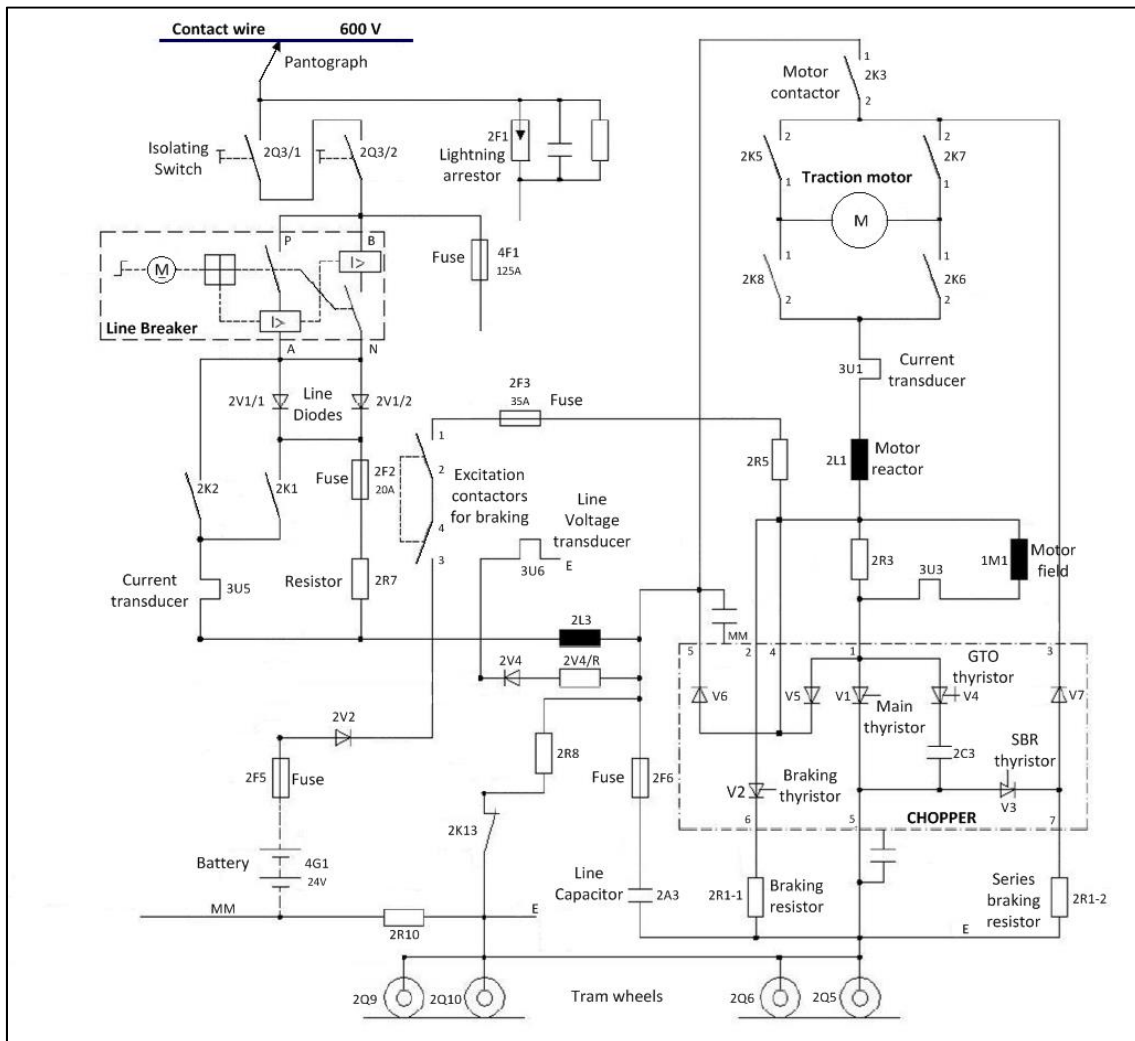

Source: Yarra Trams – Annotated by Chief Investigator, Transport Safety

2.3.3 Line Breaker

The line breaker located under the tram was a double pole, Siemens 3VK4 circuit breaker, rated to 200A maximum continuous current. It is closed when the line breaker control contactor is energised by the closing of the 24V (battery) control switch on the

² Line voltage is termed receptive (capable of receiving regenerated energy for use by other trams) if it is within a range of -20 to + 30% of the nominal 600V DC

console. The line breaker is equipped with overcurrent³ and under voltage tripping devices. Additionally, the Traction Control Unit (TCU) monitors overcurrent via the traction motor current and line current transducers. It will trip the line breaker if the line current exceeds 1300 A.

A significant flashover had occurred during the tripping of the breaker resulting in severe damage to the line breaker and the enclosure, burning a hole through the base and side (Figure 6).

Figure 6 Line Breaker and enclosure damage



Source: Chief Investigator, Transport Safety

2.3.4 Traction motor and control

The traction motors on B2 Class Tram 2109 are series-wound DC motors, operating on 600 volts. Each tram has two power bogies and one centre trailer bogie. The powered bogies are mono motor type with the traction motor mounted longitudinally within the bogie. Power is provided to the traction motor via high efficiency thyristor switch (chopper). The thyristor chopper is connected to the earth side of the traction motor and is unable to limit current in case of a motor flashover.

Inspection of the No.2 traction motor commutator showed it was severely worn and grooved. The carbon brushes were also worn and there were signs of brush chattering and sparking on the brush holder (Figure 7).

³ An instantaneous electromagnetic overcurrent trip.

Figure 7: No.2 motor commutator grooving and sparking damage

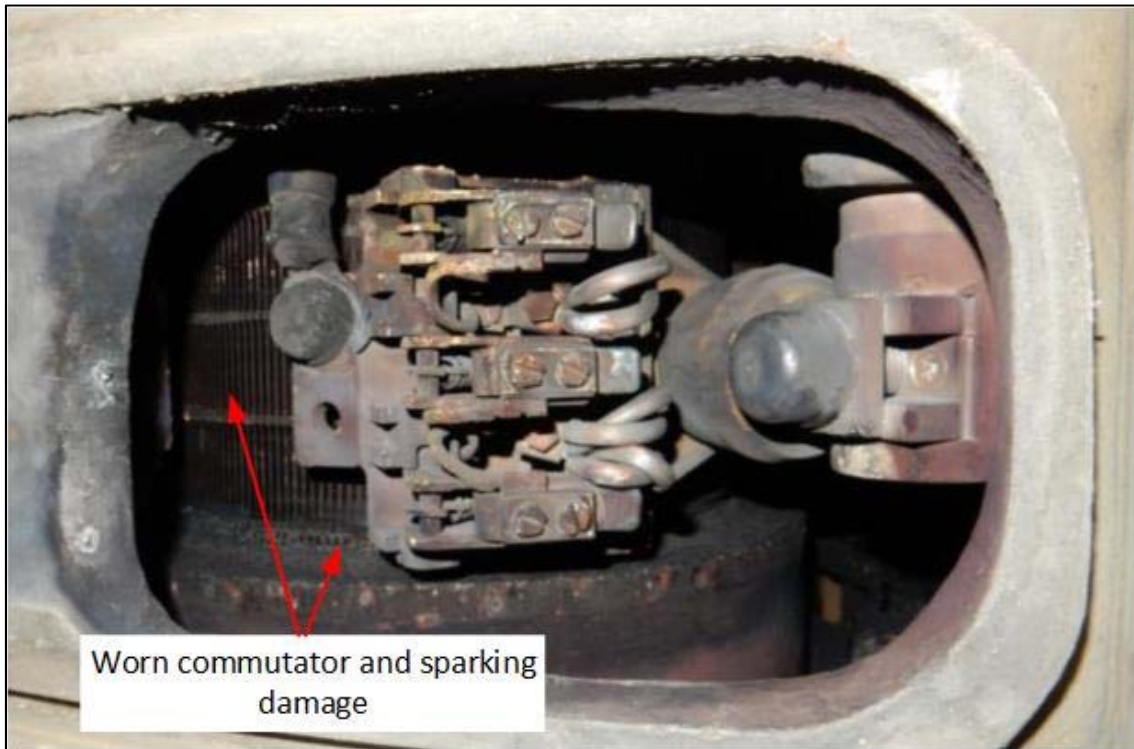

Source: Chief Investigator, Transport Safety

2.3.5 24 V auxiliary power supply system

The 24 V system supplies power to the tram control system, emergency lighting, doors and the communication system (AVM radio). The supply is provided by a static inverter that charges the 24 V battery system and provides 3 phase, 415 V at 50Hz for the tram air conditioning.

2.3.6 Tram maintenance

A Technical Maintenance Plan (TMP) details the maintenance requirements for B2 class trams. Tram Works Modules (TWM) incorporated in the TMP specify the maintenance activities at 10,000 km and 50,000 km and the 'works packages' record the actual maintenance carried out.

For traction motors, the 10,000 km service includes an inspection of the motors including measuring and replacing brushes if required and checking surface condition of the motor commutator. The Commutator should have a smooth brown patina without signs of arcing, ridges, grooves or wear marks. The visual appearance of the surface of the commutator surface is compared to a chart with acceptable/unacceptable pictures of commutator conditions. Should the condition of the commutator not be satisfactory, then the motor is required to be replaced. A 10,000 km service was carried out on this tram on 06 September 2017, which was five days prior to the incident.

The TMP also required a complete motor overhaul to be carried out at 1,000,000 km intervals. Yarra Trams advised that the motor overhaul interval had been extended from 500,000 km to 1,000,000 km during the previous franchising agreement. Yarra Trams was unable to confirm the accumulated kilometers for the motor, or whether the traction motor had been overhauled. Based on an annual 85,000 distance travelled, the

accumulated distance travelled by the tram over its service life up to the incident (27 years) would have been more than 2,000,000 km. So, the motors should have been overhauled at least twice (depending on actual kms travelled) and the records should be available.

Line breakers inspected at 10,000 km are serviced at 500,000 km and the service includes arc chute replacement, contact replacements, and repair or replacement of other components. The line breaker was also inspected during the 10,000 km service on 06 September 2017.

2.4 Similar Occurrences

On 13 May 2017, a tram was travelling along St Kilda Road when a flashover in a traction motor caused an overcurrent event that resulted in the overhead wire melting and parting. In this incident, the line breaker opened partially and did not extinguish the arc. It was found that the arc chute in the line breaker was installed incorrectly. Both HSCBs (St Kilda and Kings Way) tripped at different times, and the tram was still drawing current from one feeder even though the other substation HSCB had tripped. Further, each time the HSCBs auto re-closed, the supply was resumed to the tram, resulting in the overheating and failure of the overhead wire.

A further incident with similar circumstances occurred on Tram 2107 at Toorak Rd South Yarra, on 5 September 2017.

The Yarra Trams's investigation into the May and September 2017 incidents, recommended that traction motor overhaul interval be reduced from 1,000,000 km to 600,000 km.

3. SAFETY ANALYSIS

3.1 The incident

A flashover in No.2 traction motor resulted in an overcurrent fault in the tram electrical system. The flashover occurred during braking on a downhill grade. In braking the traction motors are used as generators and they operate under a combination of higher voltage and current compared with acceleration. Braking provides conditions in which a motor flashover is more likely.

In the event of a traction fault on a tram, the line breaker is the primary protection device. The line breaker tripped due to the high fault current and a significant flashover occurred within the line breaker enclosure during the opening of the contacts. This flashover and resulting arcing caused severe damage to the line breaker, its enclosure, and adjacent equipment and cabling. The flashover extended to the 24V system, disabling radio communications and electric door operation. In the event of failure of the traction system and the 24V system, the disc brakes apply automatically bringing the tram to a stop. It is likely that the arcing within the line breaker enclosure produced rapid heating and expansion of gases within the equipment box leading to the reported explosion, flames and smoke.

The substation network incorporating high speed circuit breakers is specifically designed to protect the overhead contact wire and associated infrastructure from overcurrent faults. The HSCB at Bundoora tripped initially. The La Trobe HSBC which was still feeding the section (and the fault) opened 7 seconds later. However, subsequent reclosing of the HSCBs at Bundoora and La Trobe, initially automatically and then remotely, resulted in the fault current continuing to be drawn through the overhead contact wire, pantograph and the damaged line breaker. The fault current drawn between the carbon contact strip of the pantograph (with the tram stationary) resulted in localised overheating and subsequent failure of the overhead contact wire. The driver had observed contact wire on the ground after the tram was stopped but prior to the explosion. The explosion was heard as the evacuation of the tram was just commencing and this would indicate that one end of the contact wire was still in contact with the pantograph.

3.2 Traction motor

A 10,000 km service was carried out on this tram five days prior to this incident. The service included a traction motor inspection that required among other things a visual inspection and assessment of the commutator.

In this instance, the commutator was in poor condition and the motor should have been replaced. Three days prior to this incident, the line breaker was recorded as opening on a line breaker fault and was also recorded as opening three times on the morning of the incident and prior to the opening that resulted in this incident.

It is likely that the No.2 traction motor that failed had not yet been overhauled. Due to a similar incident in May 2017, Yarra Trams recognized that the increase to the traction motor overhaul interval was excessive and recommended that it be reduced to 600,000 km. However, at the time of this incident, this recommendation had not been implemented.

3.3 Line Breaker

The inspection recorded that the line breaker was in good condition and no repairs, replacements or adjustments were carried out during this service. The service instructions for the line breaker required the arc chutes to be removed and inspected, and on reinstallation the contact resistance between lower arcing horn inside strip and fixed contact in the breaker to be measured.

The severe damage sustained by the line breaker made identification of the immediate cause of its failure difficult. The arc chutes were in satisfactory condition, but both sets of contacts were severely damaged. It is likely that the arc runners were not in contact, either due to incorrect installation of the arc chutes or prior damage to the arc runners. This resulted in the fault current not being cleared by the line breaker.

A recommendation in the investigation by Yarra Trams into the incident in May 2017, was that the line breaker major overhaul frequency be reduced from 500,000 km to 250,000 km. At the time of this incident, the recommendation had not been implemented by Yarra Trams.

3.4 Substation overcurrent protection

The original setting for the feeder circuit breakers at the substations was approximately 1,500 A. However, due to the addition of newer trams to the Melbourne's tram fleet that require significantly higher power, the tripping setting of the circuit breakers had been increased to approximately 3,500 A. Yarra Trams advised that the trip setting was increased to reduce 'nuisance tripping' and the setting was based on the resistance and minimum fault calculations for the section.

The circuit breaker tripping and reclosing events from the Supervisory Control and Data Acquisition (SCADA) system for each substation are listed below:

Table 1: HSCB tripping and reclosing events from SCADA system (shading indicates live overhead).

Time	Bundoora Sub (BU2)	Reclose (BU2)	La Trobe Sub (L2)	Reclose (L2)	Section Status
15:05:16	Tripped		Closed		On
15:05:23	Tripped		Tripped		Off
15:05:24	Closed	Auto	Tripped		On
15:05:28	Closed		Closed	Auto	On
15:05:34	Tripped		Closed		On
15:05:38	Tripped		Tripped		Off
15:06:13	Tripped		Closed	Remote	On
15:06:14	Unsuccessful close by control	Remote	Closed		On
15:06:18	Tripped		Tripped		Off
15:07:10	Tripped		Unsuccessful close by control	Remote	Off
15:07:16	Unsuccessful close by control	Remote	Tripped		Off

As is common with most overhead sections, this section, was fed independently from each end. Protection is also provided by HSCBs at each feed point and these will trip independently, according to the level of the current monitored at that HSCB. There is no interface between the different HSCBs at different substations feeding the same section to ensure the overhead is isolated in fault conditions. This, combined with the independent line test and reclose facility, can result in the section remaining live with

the fault condition still present. For this reason, the auto-reclose is limited to one operation and remote resetting by the Control Centre is also limited to once. Even this can result in an extended period of the contact wire remaining live.

Referring to Table 1 the independent tripping, auto-reclosing function and subsequent remote reclosing for each HSCB, meant the overhead was live for 26 seconds within the 62 seconds interval following the initial trip. This resulted in further damage to the tram equipment and the overhead contact wire melting and dropping to the ground.

Transfer trip (or synchronous) protection is available and used for DC feeder breakers by operators of other systems to ensure that faults in the DC traction system are completely isolated and fault currents are not fed from the adjacent substation, as occurred here.⁴

⁴ Pham K, Thomas R, Stinger, Jr W: *Operational and Safety Considerations for Light Rail DC Traction Electrification System Design*: Transportation Research Circular E-C058:9th National Light Rail Transit Conference

4. FINDINGS

4.1 Context

The following findings are made with respect to the Overcurrent Protection Failure of the Tram Electrical System at Plenty Road, Bundoora on 11 September 2017. These findings should not be read as apportioning blame or liability to any particular organisation or individual.

4.2 Contributing factors

- The No. 2 tram traction motor flashed over due to poor commutator condition.
- **The motor had been inspected five days prior to the incident as part of scheduled maintenance, but the motor was not exchanged as required by maintenance procedures. [Safety Issue]**
- The fault current that resulted from the motor flashover was not cleared by the tram line breaker due to the arc chutes not being installed correctly or pre-existing damage to the contact runners.
- **The tripping and reclose function operating independently at the two substations resulted in traction supply continuing even though a fault was present. This led to the eventual melting of the overhead contact wire. [Safety Issue]**

5. SAFETY ISSUES AND ACTIONS

The safety issues identified during this investigation are listed in the Findings and Safety issues and actions sections of this report. The Chief Investigator, Transport Safety expects that all safety issues identified by the investigation should be addressed by the relevant organisation. In addressing those issues, the Chief Investigator encourages relevant organisations to proactively initiate safety action.

All directly involved parties are provided with a draft report and invited to provide submissions. As part of that process, each organisation is asked to communicate what safety actions, if any, they have carried out or are planning to carry out in relation to each safety issue relevant to their organisation.

5.1 Traction motor condition

Number:	2017-04-001
Issue owner:	Yarra Trams

Safety issue description

The motor had been inspected five days prior to the incident as part of scheduled maintenance, but the motor was not exchanged as required by maintenance procedures.

Proactive action taken by Yarra Trams

Yarra Trams have inspected the line breakers and traction motors of all B Class trams. A maintenance instruction has been issued to ensure maintainer awareness of the importance of proper maintenance techniques and the timely replacement of traction motors subject to inspection results. They further advised that maintenance documentation is being currently reviewed to provide better instruction to maintenance personnel with respect to accept/reject criteria for traction motors and line breakers.

Current status of the safety issue

Issue status: Adequately addressed

5.2 Substation Circuit Breakers operating independently

Number:	2017-04-002
Issue owner:	Yarra Trams

Safety issue description

The tripping and reclose function operating independently at the two substations resulted in traction supply continuing even though a fault was present. This led to the eventual melting of the overhead contact wire.

Proactive action taken by Yarra Trams

Yarra Trams advised that typically that there are approximately 19,000 trip events per year where the circuit breakers either automatically reclose or block further operation successfully. They advised that the sequence of events that led to the trolley wire

melting at Bundoora are extremely rare and that even in this event, the automatic reclose system safely locked out power to the trolley wire when it fell to the ground.

They further advised that they are introducing a number of initiatives to improve safety through introduction of new protection standards, power system upgrades, ongoing protection relay upgrades and other works that will further improve the safety of the dc traction network.

Chief Investigator's comments in response

There have been three incidents of wires overheating and parting since May 2017. The tripping and reclose function operating independently at two or more substations that supply an overhead section can result in the section remaining live in fault condition, and therefore an increased risk to passengers and members of the public. Accordingly, the Chief Investigator issues the following Safety Recommendation.

Safety action recommended by the Chief Investigator

It is recommended that Yarra Trams review protection technologies available to mitigate the risk presented by an overhead section remaining live with the fault condition still present as a result of one substation only tripping. This review should encompass a review of technology and other solutions to ensure that substations only reclose when a fault has cleared.

5.3 Additional safety actions

Yarra Trams advised the following additional safety actions:

- A modification to the 24V electrical system has been completed across the B Class fleet to ensure 24V system integrity in the event of line breaker failure.
- Emergency door release signs have been applied across the B Class fleet to enable location and activation of the emergency door release by passengers should the driver be unable to do so.
- A safety alert has been issued to drivers that all issues involving line breakers are reported immediately to the Operation Centre for monitoring and assistance.
- A new type of High Speed Circuit Breaker (HSCB) is currently undergoing tests as a replacement for the original line breaker.
- New protection setting standards have been introduced, which include the incorporation of protection curves to manage the trolley wire and cable screens on the on the network.
- Implemented a protection relay upgrade program to introduce modern relays with ability to program additional protection for trolley wires, with multiple event recording to enable improvements in understanding of fault events and protection management.
- Are installing new substations with modern protection relays and new feeder cables as part of the Power Supply Upgrade Project. These substations will allow electrical sections to be shortened and feeder systems to be enhanced, improving electrical protection.

- Are currently upgrading the power system alarm systems that will enable improved monitoring of sections, enable greater understanding of load profiles to improve protection designs.